

HORIZONTAL BELT DRYER

FEATURES

- Modular structure and ease of assembly
- Oscillating feeder mechanism
- Air dampers with proportional servo motor
- Easy-to-maintain air filters
- Adjustable-speed belt and fan drive
- Air curtains providing sealing between compartments
- Under-chain sweepers and spring augers for fines
- Adjustable levelling feet for balanced load distribution
- Safe structure equipped with sensors for all moving units



PETS



FISH



BIOMASS



CHEMICALS



FOOD



DHBD SERIES HORIZONTAL BELT DRYER

DHBD series dryers are used to make the product suitable for processes such as packaging, storage and transportation by removing excess moisture from the product through heat and mass transfer. The product, whose water activity decreases with the drying process, can be transferred to the next processes in a more sterile and stable state.

In the horizontal dryer, whose length and height can be adjusted thanks to its modular structure, excess moisture is removed from the product with the increased moisture holding ability of the air heated by steam radiators.

It is designed to provide the desired humidity reduction in optimum energy and time, thanks to its adjustable-speed air flow, radiator thermal capacity and conveyor belt speed.

INDUSTRIES

- Pet Food Plants
- Aquatic Feed Mills
- Food Industries
- Biomass Factories

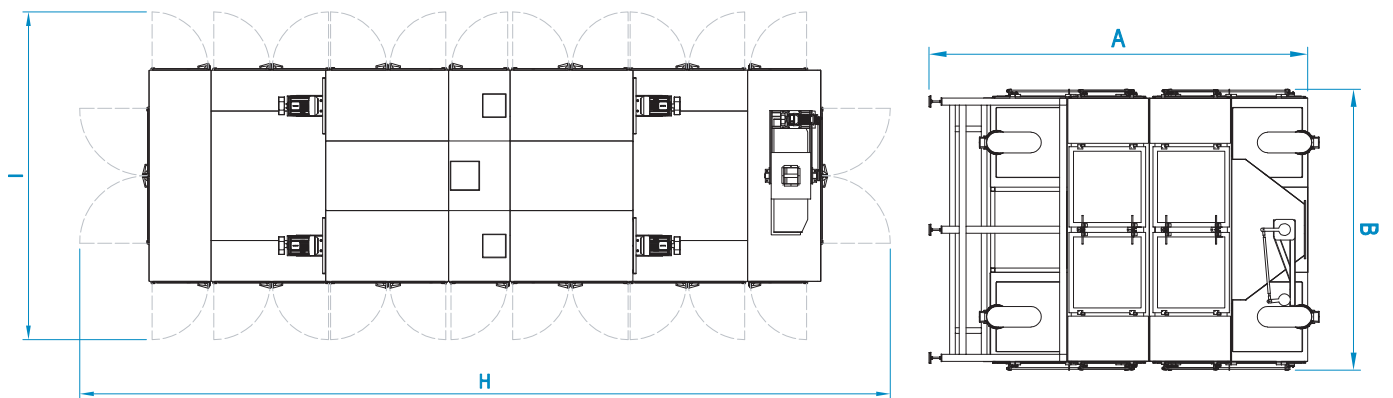
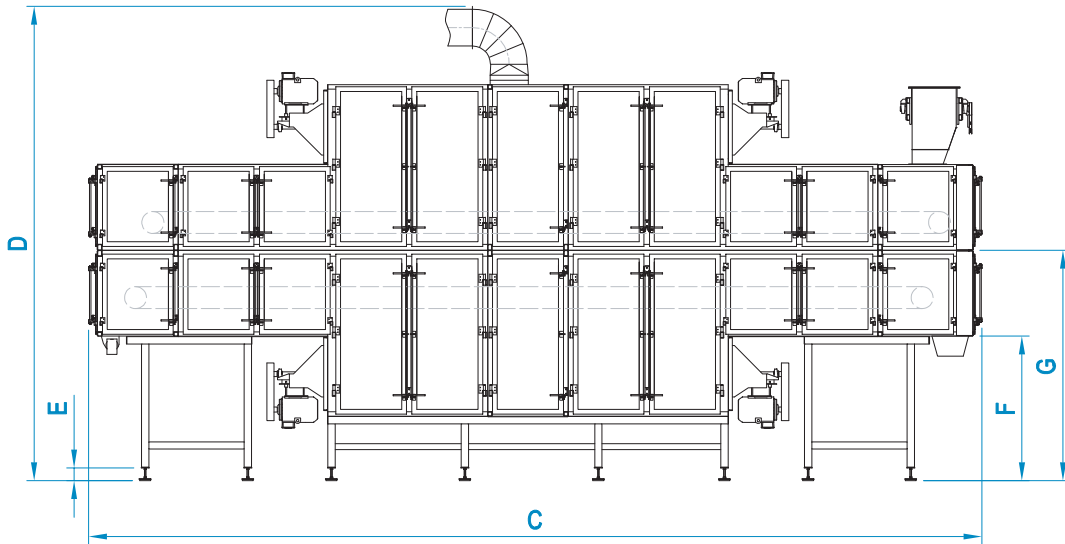

MODEL	CAPACITY (tph)	MOTOR (kW)	DIMENSIONS (mm)								
			A	B	C	D (min)	E (max)	F	G	H	I
DHBD-2000x10000	5	8x22	5400	4000	12200	6300	170	1970	3140	14400	5850

600 Evler Mah. Balıkesir Asf. Sol Taraf No: 96, 10201 Bandırma / Balıkesir
 P: +90 266 733 83 63 (3 Lines) • F: +90 266 733 83 66

[f](#) [in](#) [ig](#) [yt](#) | yemmak.com

